

## SBT - SPRING RETURN BOLT TENSIONERS - IMPERIAL



Capacities from 457 to 2649 kN

Maximum working pressure 1500 Bar

Spring assisted piston retraction

The SBT imperial range of hydraulic bolt tensioners, offers all of the features and benefits of our standard STS range (see pages 102 and 103), but with the added feature of spring assisted return hydraulic pistons. Designed primarily for topside operation, this additional spring return piston feature will reduce bolt tensioning cycle times considerably, as the tensioner pistons will automatically start to retract, after the hydraulic pressure is released. The range currently comprises of 22 models, suitable for standard size bolts from 1¼" to 4" diameter.

G

The versatility of the SBT bolt tensioner range, is identical to our standard STS range, with a variety of interchangeable threaded pullers and nut rotating sockets available, either as bolt size conversion kits or individual parts. Further details on SBT imperial conversion kits are detailed on pages 96 & 97. All SBT bolt tensioners are designed and manufactured with a wear coated piston, maximum stroke indicator, self energising high pressure seals, dual quick connect couplers, for easy multiple tensioner hook up and operate at pressures up to 1500 Bar maximum.

Suitable hydraulic pumps and high pressure hydraulic hose assemblies for use with SBT tensioners are detailed on pages 115 & 116 of this catalogue.

- >> Nitrocarburised piston
- >> Maximum piston stroke indicator
- >> Spring assisted return
- >> User friendly operating and maintenance procedure



Don't forget to order your tommy bars when purchasing Hi-Force hydraulic tensioners. We recommend the purchase of one tommy bar for every four hydraulic tensioners.

| Tensioner range | Tommy bar |
|-----------------|-----------|
| SBT2            | TTB08     |
| SBT3            | TTB10     |
| SBT4            | TTB10     |
| SBT5            | TTB14     |
| SBT6            | TTB14     |

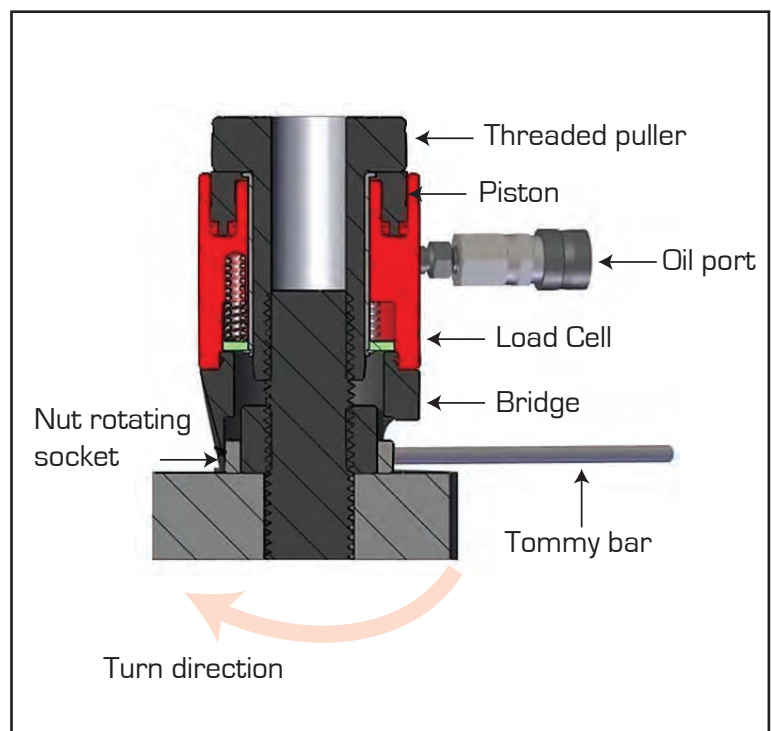

## SBT - SPRING RETURN BOLT TENSIONERS - IMPERIAL



Bolt sizes from 1 1/4" to 4"

Modular design for optimum versatility

Dual quick connect couplings for easy connection



Conversion kits for SBT imperial range of bolt tensioners can be found on pages 96 and 97 of this catalogue.

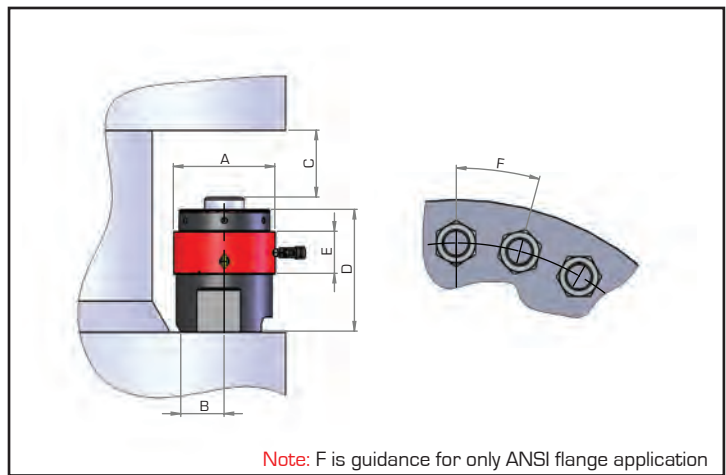

G

| Model number | Bolt thread size | Threads per inch | Capacity kN | Capacity tonnes | Effective area cm <sup>2</sup> | Stroke mm | Weight kg |
|--------------|------------------|------------------|-------------|-----------------|--------------------------------|-----------|-----------|
| SBT2-125B1   | 1 1/4"           | 8                | 457         | 46.6            | 30.5                           | 15        | 4.0       |
| SBT2-137B1   | 1 3/8"           | 8                | 457         | 46.6            | 30.5                           | 15        | 4.0       |
| SBT2-150B1   | 1 1/2"           | 8                | 457         | 46.6            | 30.5                           | 15        | 4.0       |
| SBT3-162B1   | 1 5/8"           | 8                | 822         | 83.8            | 54.8                           | 15        | 6.7       |
| SBT3-175B1   | 1 3/4"           | 8                | 822         | 83.8            | 54.8                           | 15        | 6.7       |
| SBT3-175B2   | 1 3/4"           | 8                | 822         | 83.8            | 54.8                           | 15        | 6.7       |
| SBT3-187B1   | 1 7/8"           | 8                | 822         | 83.8            | 54.8                           | 15        | 6.7       |
| SBT3-187B2   | 1 7/8"           | 8                | 822         | 83.8            | 54.8                           | 15        | 6.7       |
| SBT3-200B2   | 2"               | 8                | 822         | 83.8            | 54.8                           | 15        | 6.7       |
| SBT4-187B1   | 1 7/8"           | 8                | 1264        | 128.9           | 84.3                           | 15        | 11.0      |
| SBT4-200B1   | 2"               | 8                | 1264        | 128.9           | 84.3                           | 15        | 11.0      |
| SBT4-200B2   | 2"               | 8                | 1264        | 128.9           | 84.3                           | 15        | 11.0      |
| SBT4-225B2   | 2 1/4"           | 8                | 1264        | 128.9           | 84.3                           | 15        | 11.0      |
| SBT4-250B2   | 2 1/2"           | 8                | 1264        | 128.9           | 84.3                           | 15        | 11.0      |
| SBT5-250B1   | 2 1/2"           | 8                | 1833        | 186.9           | 122.2                          | 15        | 16.5      |
| SBT5-275B1   | 2 3/4"           | 8                | 1833        | 186.9           | 122.2                          | 15        | 16.5      |
| SBT5-300B1   | 3"               | 8                | 1833        | 186.9           | 122.2                          | 15        | 16.5      |
| SBT6-300B1   | 3"               | 8                | 2649        | 270.0           | 176.6                          | 15        | 24.0      |
| SBT6-325B1   | 3 1/4"           | 8                | 2649        | 270.0           | 176.6                          | 15        | 24.0      |
| SBT6-350B1   | 3 1/2"           | 8                | 2649        | 270.0           | 176.6                          | 15        | 24.0      |
| SBT6-375B3   | 3 3/4"           | 8                | 2649        | 270.0           | 176.6                          | 15        | 24.0      |
| SBT6-400B3   | 4"               | 8                | 2649        | 270.0           | 176.6                          | 15        | 24.0      |

| Dimensions in mm |     |       |     |     |     |
|------------------|-----|-------|-----|-----|-----|
| A                | B   | C min | D   | E   | F   |
| 102              | 39  | 127   | 164 | 91  | 74  |
| 102              | 39  | 127   | 164 | 91  | 77  |
| 102              | 39  | 123   | 164 | 91  | 80  |
| 137              | 47  | 146   | 188 | 94  | 92  |
| 137              | 47  | 143   | 188 | 94  | 93  |
| 137              | 50  | 148   | 193 | 94  | 94  |
| 137              | 47  | 139   | 188 | 94  | 97  |
| 137              | 50  | 144   | 193 | 94  | 104 |
| 137              | 50  | 141   | 193 | 94  | 104 |
| 167              | 50  | 147   | 197 | 97  | 104 |
| 167              | 50  | 143   | 197 | 97  | 104 |
| 167              | 62  | 155   | 213 | 97  | 106 |
| 167              | 62  | 150   | 213 | 97  | 121 |
| 167              | 62  | 145   | 213 | 97  | 127 |
| 209              | 73  | 162   | 229 | 102 | 134 |
| 209              | 73  | 156   | 229 | 102 | 140 |
| 209              | 73  | 149   | 229 | 102 | 147 |
| 246              | 84  | 174   | 254 | 103 | 161 |
| 246              | 84  | 169   | 254 | 103 | 167 |
| 246              | 84  | 162   | 254 | 103 | 172 |
| 246              | 105 | 194   | 295 | 103 | 191 |
| 246              | 105 | 189   | 295 | 103 | 196 |

Note: Weight is for load cell and bridge only. Total weight of complete assembly depends on size of puller and nut rotating socket selected. Tommy bars are not included. Hi-Force recommends one tommy bar for every four tensioners, please see page 94 for ordering code.