

'C' Type RC 1200 Series

Long Reach, Self Feeding with Adjustable Reversible Bearing Housing

This range of tools is fitted with a reversible bearing housing assembly. This type of housing allows you to set a 3mm standoff on the first tubesheet and a varying standoff of up to 25mm on the second tubesheet. This deeper recess allows the expanded joint to flow unrestricted thus preventing tubes from bending and excessive stresses building up in tube bundle. Excessive standoff can be trimmed back using a tube end facer (see page 39 for details).

EXPANDER with 1 1/2" (38.10mm) long Rollers

X = 1 1/2" (38.10mm)
Y = 5 1/4" (133.35 mm)

Effective parallel rolling length 1 1/4" (31.75mm)

EXPANDER with 2 1/4" (57.15m) long Rollers

X = 2 1/4" (57.15mm)
Y = 6" (152.40mm)

Effective parallel rolling length 2" (50.80mm)

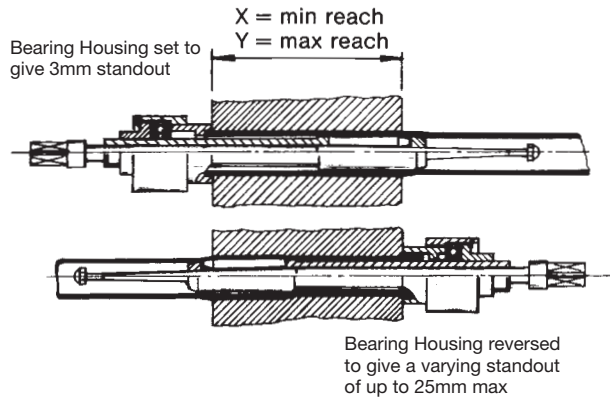

Tube Expanders fitted with 5 rollers are available for expanding thin wall and titanium tubes. Please speak to our sales team for more information.

TABLE RELATING

Tube O.D.	Tube Thickness		Min. I.D. Tube Tool Enters		Maximum Expansion of Tool		■ Size Sq. on Mandrel		EXPANDER with 1 1/2" (38.10mm) long Rollers			Expander with 2 1/4" (57.15mm) long Rollers			
	ins	mm	g'ge	mm	ins	mm	ins	mm	ins	mm	Complete Tool No.	Mandrel No.	Set of Rollers No.	Complete Tool No.	Mandrel No.
1/2	12.70	14	2.03	.333	8.45	.375	9.52	1/4	6.35	RC1200S	CM1200S	CR0			
1/2	12.70	15	1.83	.344	8.74	.394	10.00	1/4	6.35	RC1200	CM50	CR0			
1/2	12.70	16	1.63	.360	9.14	.410	10.41	1/4	6.35	RC1201	CM51	CR1			
1/2	12.70	17	1.42	.374	9.50	.424	10.77	1/4	6.35	RC1203	CM51	CR2			
1/2	12.70	18	1.22	.392	9.96	.447	11.35	3/8	9.53	RC1205	CM52	CR3			
5/8	15.88	12	2.64	.392	9.96	.447	11.35	3/8	9.53	RC1205	CM52	CR3			
5/8	15.88	13	2.34	.425	10.79	.480	12.19	3/8	9.53	RC1207	CM53	CR4			
5/8	15.88	14	2.03	.449	11.40	.509	12.93	3/8	9.53	RC1209	CM54	CR4	RC1210	CM54	CR4A
5/8	15.88	15	1.83	.471	11.96	.536	13.61	3/8	9.53	RC1211	CM55	CR5	RC1212	CM55	CR5A
5/8	15.88	16	1.63	.485	12.32	.550	13.97	3/8	9.53	RC1213	CM55	CR6	RC1214	CM55	CR6A
5/8	15.88	17	1.42	.499	12.67	.564	14.33	3/8	9.53	RC1215	CM56	CR6	RC1216	CM56	CR6A
5/8	15.88	18	1.22	.517	13.13	.572	14.53	3/8	9.53	RC1217	CM57	CR7	RC1218	CM57	CR7A
3/4	19.05	10	3.25	.471	11.96	.536	13.61	3/8	9.53	RC1211	CM55	CR5	RC1212	CM55	CR5A
3/4	19.05	11	2.95	.499	12.67	.564	14.33	3/8	9.53	RC1215	CM56	CR6	RC1216	CM56	CR6A
3/4	19.05	12	2.64	.522	13.26	.582	14.78	3/8	9.53	RC1219	CM56	CR7	RC1220	CM56	CR7A
3/4	19.05	13	2.34	.550	13.97	.615	15.62	3/8	9.53	RC1221	CM58	CR8	RC1222	CM58	CR8A
3/4	19.05	14	2.03	.574	14.58	.639	16.23	3/8	9.53	RC1223	CM58	CR9	RC1224	CM58	CR9A
3/4	19.05	15	1.83	.596	15.14	.661	16.79	3/8	9.53	RC1225	CM58	CR10	RC1226	CM58	CR10A
3/4	19.05	16	1.63	.605	15.37	.685	17.40	3/8	9.53	RC1227	CM59	CR10	RC1228	CM59	CR10A
3/4	19.05	17	1.42	.619	15.72	.699	17.75	3/8	9.53	RC1229	CM59	CR11	RC1230	CM59	CR11A
3/4	19.05	18	1.22	.619	15.72	.699	17.75	3/8	9.53	RC1229	CM59	CR11	RC1230	CM59	CR11A
7/8	22.23	10	3.25	.596	15.14	.661	16.79	3/8	9.53	RC1225	CM58	CR10	RC1226	CM58	CR10A
7/8	22.23	11	2.95	.619	15.72	.699	17.75	3/8	9.53	RC1229	CM59	CR11	RC1230	CM59	CR11A
7/8	22.23	12	2.64	.642	16.30	.722	18.34	3/8	9.53	RC1231	CM59	CR12	RC1232	CM59	CR12A
7/8	22.23	13	2.34	.670	17.02	.750	19.05	3/8	9.53	RC1233	CM60	CR13	RC1234	CM60	CR13A

NOTE – Mandrels supplied with square shank unless otherwise specially ordered

WICKSTEED ENGINEERING LIMITED

Hove Road, Rushden, Northamptonshire NN10 0JB • Tel: +44 (0)1933 318555 • Fax: +44 (0)1933 410103 • Email: mail@wicksteed.com
www.wicksteed.com

'C' Type RC 1200 Series

(continued)

Tube O.D.		Tube Thickness		Min. I.D. Tube Tool Enters		Maximum Expansion of Tool		Size Sq. on Mandrel		EXPANDER with 1 1/2" (38-10mm) long Rollers			Expander with 2 1/4" (57-15mm) long Rollers		
ins	mm	g'ge	mm	ins	mm	ins	mm	ins	mm	Complete Tool No.	Mandrel No.	Set of Rollers No.	Complete Tool No.	Mandrel No.	Set of Rollers No.
7/8	22.23	14	2.03	.685	17.40	.774	19.66	3/8	9.53	RC1235	CM61	CR14	RC1236	CM61	CR14A
7/8	22.23	15	1.83	.712	18.08	.801	20.35	3/8	9.53	RC1237	CM61	CR15	RC1238	CM61	CR15A
7/8	22.23	16	1.63	.726	18.44	.815	20.70	3/8	9.53	RC1239	CM62	CR15	RC1240	CM62	CR15A
1	25.40	8	4.06	.655	16.64	.735	18.67	3/8	9.53	RC1241	CM59	CR13	RC1242	CM59	CR13A
1	25.40	9	3.66	.685	17.40	.774	19.66	3/8	9.53	RC1235	CM61	CR14	RC1236	CM61	CR14A
1	25.40	10	3.25	.712	18.08	.801	20.35	3/8	9.53	RC1237	CM61	CR15	RC1238	CM61	CR15A
1	25.40	11	2.95	.740	18.80	.829	21.06	3/8	9.53	RC1243	CM62	CR16	RC1244	CM62	CR16A
1	25.40	12	2.64	.763	19.58	.852	21.64	3/8	9.53	RC1245	CM62	CR17	RC1246	CM62	CR17A
1	25.40	13	2.34	.791	20.10	.880	22.35	3/8	9.53	RC1247	CM62	CR18	RC1248	CM62	CR18A
1	25.40	14	2.03	.810	20.57	.909	23.09	3/8	9.53	RC1249	CM63	CR18	RC1250	CM63	CR18A
1	25.40	15	1.83	.837	21.26	.936	23.77	3/8	9.53	RC1251	CM63	CR19	RC1252	CM63	CR19A
1	25.40	16	1.63	.837	21.26	.936	23.77	3/8	9.53	RC1251	CM63	CR19	RC1252	CM63	CR19A
1 1/8	28.58	8	4.06	.776	19.71	.875	22.23	3/8	9.53	RC1253	CM63	CR20	RC1254	CM63	CR20A
1 1/8	28.58	9	3.66	.810	20.57	.909	23.09	3/8	9.53	RC1249	CM63	CR18	RC1250	CM63	CR18A
1 1/8	28.58	10	3.25	.837	21.26	.936	23.77	3/8	9.53	RC1251	CM63	CR19	RC1252	CM63	CR19A
1 1/8	28.58	11	2.95	.865	21.97	.964	24.97	3/8	9.53	RC1255	CM63	CR21	RC1256	CM63	CR21A
1 1/8	28.58	12	2.64	.883	22.43	.982	24.94	1/2	12.70	RC1257	CM64	CR21	RC1258	CM64	CR21A
1 1/8	28.58	13	2.34	.916	23.27	1.015	25.78	1/2	12.70	RC1259	CM64	CR22	RC1260	CM64	CR22A
1 1/8	28.58	14	2.03	.935	23.75	1.044	26.52	1/2	12.70	RC1261	CM65	CR23	RC1262	CM65	CR23A
1 1/8	28.58	15	1.83	.962	24.43	1.071	27.20	1/2	12.70	RC1263	CM65	CR24	RC1264	CM65	CR24A
1 1/8	28.58	16	1.63	.962	24.43	1.071	27.20	1/2	12.70	RC1263	CM65	CR24	RC1264	CM65	CR24A
1 1/4	31.75	8	4.06	.901	22.89	1.010	25.65	1/2	12.70	RC1265	CM65	CR25	RC1266	CM65	CR25A
1 1/4	31.75	9	3.66	.935	23.75	1.044	26.52	1/2	12.70	RC1261	CM65	CR23	RC1262	CM65	CR23A
1 1/4	31.75	10	3.25	.962	24.43	1.071	27.20	1/2	12.70	RC1263	CM65	CR24	RC1264	CM65	CR24A
1 1/4	31.75	11	2.95	.990	25.15	1.099	27.91	1/2	12.70	RC1267	CM66	CR26	RC1268	CM66	CR26A
1 1/4	31.75	12	2.64	1.013	25.73	1.122	28.49	1/2	12.70	RC1269	CM66	CR27	RC1270	CM66	CR27A
1 1/4	31.75	13	2.34	1.041	26.44	1.150	29.21	1/2	12.70	RC1271	CM67	CR28	RC1272	CM67	CR28A
1 1/4	31.75	14	2.03	1.060	26.92	1.169	29.70	1/2	12.70	RC1273	CM67	CR29	RC1274	CM67	CR29A
1 1/4	31.75	15	1.83	1.087	27.61	1.196	30.38	1/2	12.70	RC1275	CM67	CR30	RC1276	CM67	CR30A
1 1/4	31.75	16	1.63	1.087	27.61	1.196	30.38	1/2	12.70	RC1275	CM67	CR30	RC1276	CM67	CR30A
1 3/8	34.93	8	4.06	1.026	26.06	1.135	28.83	1/2	12.70	RC1277	CM67	CR31	RC1278	CM67	CR31A
1 3/8	34.93	9	3.66	1.060	26.92	1.169	29.70	1/2	12.70	RC1273	CM67	CR29	RC1274	CM67	CR29A
1 3/8	34.93	10	3.25	1.087	27.61	1.196	30.38	1/2	12.70	RC1275	CM67	CR30	RC1276	CM67	CR30A
1 3/8	34.93	11	2.95	1.115	28.12	1.224	31.09	1/2	12.70	RC1279	CM68	CR30	RC1280	CM68	CR30A
1 3/8	34.93	12	2.64	1.133	28.78	1.242	31.55	1/2	12.70	RC1281	CM68	CR32	RC1282	CM68	CR32A
1 3/8	34.93	13	2.34	1.160	29.46	1.275	32.38	1/2	12.70	RC1283	CM69	CR33	RC1284	CM69	CR33A
1 3/8	34.93	14	2.03	1.179	29.95	1.294	32.87	1/2	12.70	RC1285	CM70	CR34	RC1286	CM70	CR34A
1 3/8	34.93	15	1.83	1.206	30.63	1.321	33.55	1/2	12.70	RC1287	CM70	CR35	RC1288	CM70	CR35A
1 3/8	34.93	16	1.63	1.206	30.63	1.321	33.55	1/2	12.70	RC1287	CM70	CR35	RC1288	CM70	CR35A
1 1/2	38.10	8	4.06	1.145	29.08	1.260	32.00	1/2	12.70	RC1289	CM69	CR34	RC1290	CM69	CR34A
1 1/2	38.10	9	3.66	1.179	29.95	1.294	32.87	1/2	12.70	RC1285	CM70	CR34	RC1286	CM70	CR34A
1 1/2	38.10	10	3.25	1.206	30.63	1.321	33.55	1/2	12.70	RC1287	CM70	CR35	RC1288	CM70	CR35A
1 1/2	38.10	11	2.95	1.235	31.39	1.350	34.29	1/2	12.70	RC1291	CM70	CR36	RC1292	CM70	CR36A
1 1/2	38.10	12	2.64	1.257	31.93	1.372	34.85	1/2	12.70	RC1293	CM70	CR37	RC1294	CM70	CR37A
1 1/2	38.10	13	2.34	1.285	32.64	1.400	35.56	1/2	12.70	RC1295	CM71	CR37	RC1296	CM71	CR37A
1 1/2	38.10	14	2.03	1.285	32.64	1.400	35.56	1/2	12.70	RC1295	CM71	CR37	RC1296	CM71	CR37A
1 1/2	38.10	15	1.83	1.331	33.81	1.446	36.73	1/2	12.70	RC1297	CM71	CR38	RC1298	CM71	CR38A
1 1/2	38.10	16	1.63	1.331	33.81	1.446	36.73	1/2	12.70	RC1297	CM71	CR38	RC1298	CM71	CR38A

NOTE – Mandrels supplied with square shank unless otherwise specially ordered

WICKSTEED ENGINEERING LIMITED

Hove Road, Rushden, Northamptonshire NN10 0JB • Tel: +44 (0)1933 318555 • Fax: +44 (0)1933 410103 • Email: mail@wicksteed.com
www.wicksteed.com